

DATA SHEET

O 5.21

ROTARY VANE VACUUM PUMPS

oil-lubricated

air-cooled

MAKE IT BECKER.



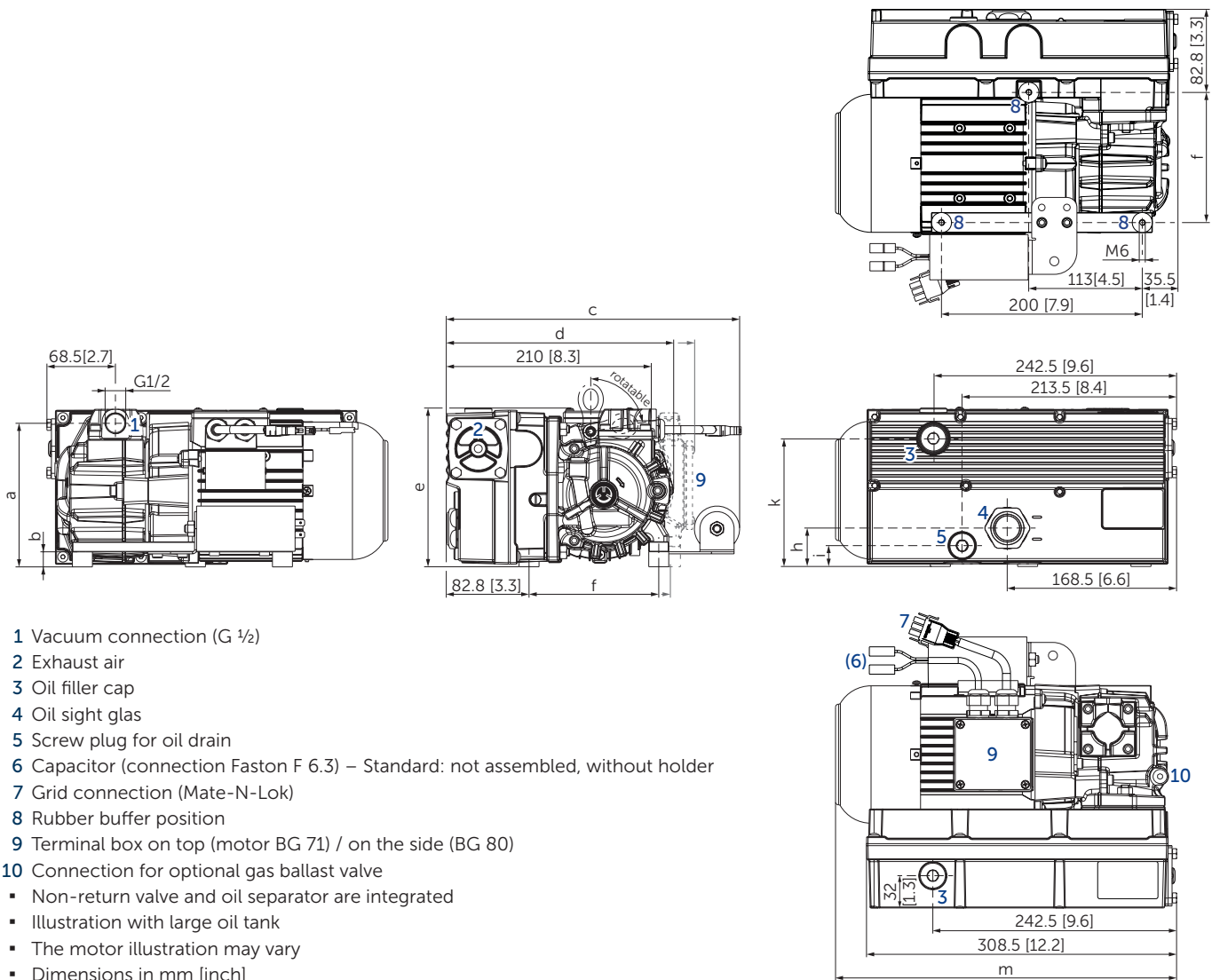

- 1 Vacuum connection (G 1/2)
- 2 Exhaust air
- 3 Oil filler cap
- 4 Oil sight glass
- 5 Screw plug for oil drain
- 6 Capacitor (connection Faston F 6.3) – Standard: not assembled, without holder
- 7 Grid connection (Mate-N-Lok)
- 8 Rubber buffer position
- 9 Terminal box on top (motor BG 71) / on the side (BG 80)
- 10 Connection for optional gas ballast valve
 - Non-return valve and oil separator are integrated
 - Illustration with large oil tank
 - The motor illustration may vary
 - Dimensions in mm [inch]

Motor	a	b	c	d	e	f	h	i	k	m
BG 71	143.6[5.7]	15[0.6]	267[10.5]	225.2[8.9]	158.0[6.2]	129.7[5.1]	38.1[1.5]	20.6[0.8]	127.6[5.0]	340.0[13.4]
BG 80	148.6[5.9]	20[0.8]	295[11.6]	247.1[9.7]	162.6[6.4]	140.2[5.5]	43.1[1.7]	25.6[1.0]	132.6[5.2]	353.5[13.9]

Nominal capacity		Vacuum absolute		Emission sound pressure level ¹⁾		Weight incl. motor	Oil	
m ³ /h		mbar	kPa	dB(A)		kg	l	Becker Lube ²⁾
50 Hz	60 Hz	50 & 60 Hz	50 & 60 Hz	50 Hz	60 Hz			
23.5	27.0	2	0.2	64	69	≈20.0/21.5 ³⁾	0.5/0.3 ³⁾	M 68 / M 32 (mineral) S 68 / S 32 (synthetic) SL 68 / SL 32 (food)

¹⁾ According to DIN EN ISO 11203, accuracy class of measurement: class 2, extended measurement uncertainty: 3 dB
1 m [39.4 inch] distance, at medium load, vacuum connection piped, exhaust side open

²⁾ See operating instructions

³⁾ Large/small oil tank

1~ Motors										
#	50 Hz				60 Hz				Weight kg	Version
	kW	V	min ⁻¹	A	kW	V	min ⁻¹	A		
01	0.75	220–240	2790–2820	4.9			–		12.0	IP 55, ISO F, bimetal capacitor 30 µF (450V) motor size BG 71 ¹⁾
02	0.75	220–240	2830–2860	5.2–5.5	0.9	220–240	3340–3400	6.0–5.5	12.8	IP 55, ISO F, bimetal capacitor 30 µF (450V) motor size BG 80 ²⁾
03	0.75	100–110	2800–2840	11.3–11.7	0.9	100–120	3250–3400	13.4–11.6	13.2	IP 55, ISO F, bimetal capacitor 100 µF (330V) motor size BG 80 ²⁾

3~ Motors										
#	50 Hz				60 Hz				Weight kg	Version
	kW	V	min ⁻¹	A	kW	V	min ⁻¹	A		

on request

¹⁾ Terminal box on top (BG 71)

²⁾ Terminal box on the side (BG 80)

• Current consumption and rotation speed may vary. Tolerance in each case -1.5/+2%

+ VARIANTS AND ACCESSORIES

SMALL OIL TANK (0.3 L)

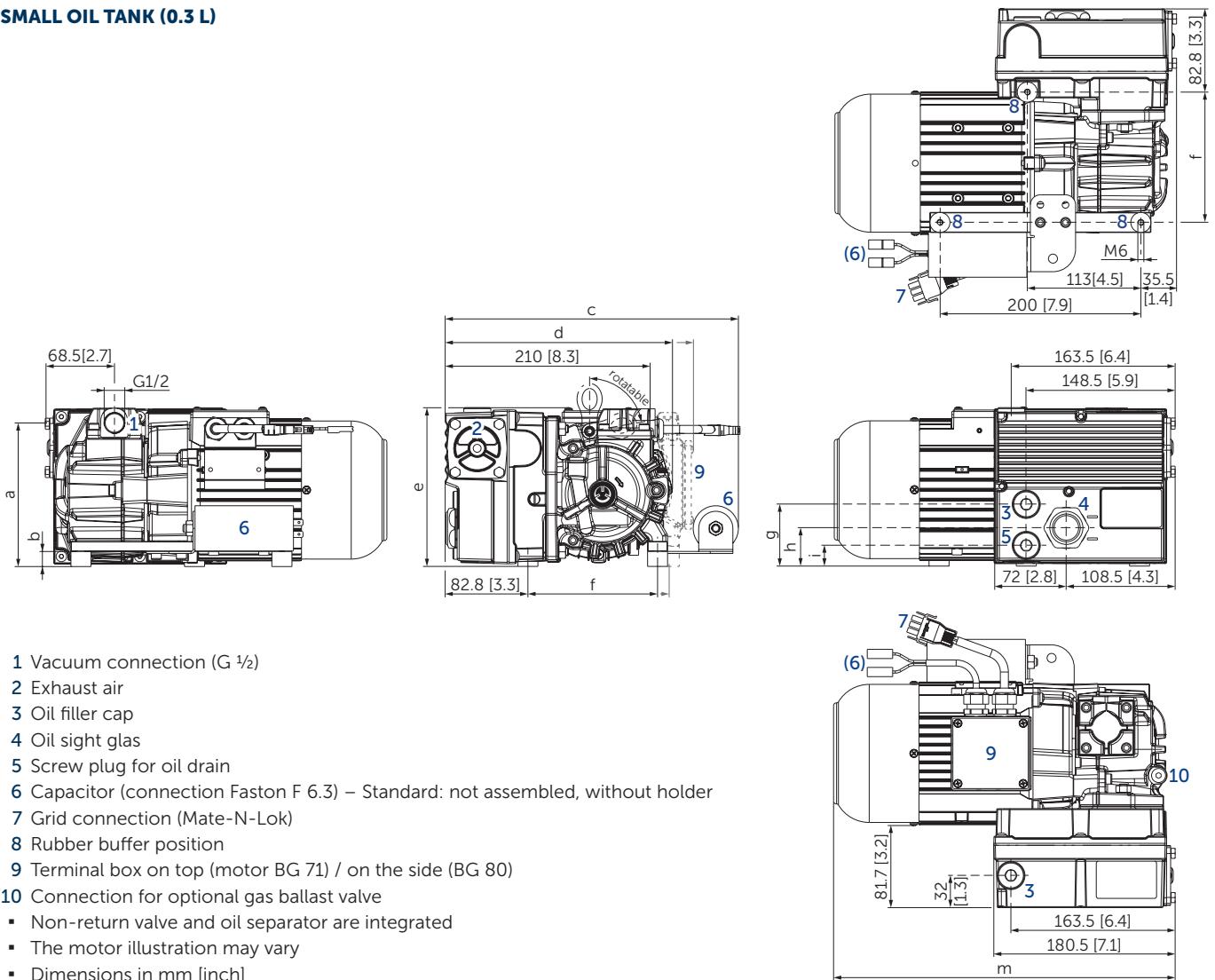

- 1 Vacuum connection (G ½)
- 2 Exhaust air
- 3 Oil filler cap
- 4 Oil sight glas
- 5 Screw plug for oil drain
- 6 Capacitor (connection Faston F 6.3) – Standard: not assembled, without holder
- 7 Grid connection (Mate-N-Lok)
- 8 Rubber buffer position
- 9 Terminal box on top (motor BG 71) / on the side (BG 80)
- 10 Connection for optional gas ballast valve
 - Non-return valve and oil separator are integrated
 - The motor illustration may vary
 - Dimensions in mm [inch]

Motor	a	b	c	d	e	f	g	h	i	m
BG 71	143.6[5.7]	15[0.6]	267[10.5]	225.2[8.9]	158.0[6.2]	129.7[5.1]	61.6[2.4]	38.1[1.5]	20.6[0.8]	340.0[13.4]
BG 80	148.6[5.9]	20[0.8]	295[11.6]	247.1[9.7]	162.6[6.4]	140.2[5.5]	66.6[2.6]	43.1[1.7]	25.6[1.0]	353.5[13.9]

GAS BALLAST VALVE

- Version for small amounts of moisture, vacuum <3 mbar
- Version for higher amounts of moisture, vacuum <20 mbar

CAPACITOR HOLDER

- See drawings

BECKER LUBE

M 68	mineral	1.00 l	Nº 96002300300	5.00 l	Nº 96002300400
S 68	synthetic	1.00 l	Nº 96002300500	5.00 l	Nº 96002300600
SL 68	food	1.00 l	Nº 96002300700	5.00 l	Nº 96002300800
M 32	mineral	0.25 l	Nº 96001700025		
S 32	synthetic	0.25 l	Nº 96000320025	0.50 l	Nº 96000320050
SL 32	food	0.25 l	Nº 96001800025		

- See operating instructions



MAKE IT BECKER.