

ROBUSCH®

by Gardner Denver

Premium Solutions for Gas and Biogas Handling



Premium Solutions for Gas and Biogas Handling

State-of-the-art technologies for the most demanding process gas and biogas applications

Robuschi has an application oriented approach: firstly they understand the process and then they offer the best according to the client's demand. The result is a high performance solution.

Robuschi high specification process gas blower units are custom designed for process-critical applications. We produce skid-mounted packages offering a number of advantages across a range of applications that demand reliability, cost-efficiency and robustness.

The Robuschi packages are capable of handling a mixture of gases in applications where contamination is an issue, and can be designed to incorporate all the necessary drives, control and management systems, instruments and ancillary processing equipment ready for straightforward installation and commissioning.

Benefits at a glance

Pressure up to 1,000 mbar(g) and above upon request

Vacuum up to 100 mbar(g)

Capacity up to 25,000 m³/h

- Robust construction
- Reliable
- Long uptime and low service costs
- Customised solutions
- ATEX certified



Recovery of methane from mines



Process gas recovery



Nitrogen pneumatic conveying



Nitrogen handling

Type of gas	Applications	Application requisites	Specific characteristics of the blower unit
Biogas	Transfer from digestion tower to energy co-generation system (endothermic motor) or heat (boiler)	<ul style="list-style-type: none"> • Corrosion resistance • No dispersion of biogas in the environment • Management of pressure peaks downstream, and precise capacity adjustment on co-generation systems • User-friendly • Safe risk management 	<ul style="list-style-type: none"> • The materials in contact with the gas are corrosion-resistant • Gas tight configuration of the blower (air end) and relative accessories • Recirculation system on relief valve • Simple construction with wide range of accessories for various application needs • ATEX configuration and certification
	Transfer of biogas from digestion tower(s) to upgrading systems, to produce biomethane	<ul style="list-style-type: none"> • Corrosion resistance (on silencers too) • Accurate control of the operating parameters • No dispersion of biogas in the environment • Management of pressure peaks downstream, and precise capacity adjustment on co-generation systems • Safe risk management 	<ul style="list-style-type: none"> • The materials in contact with the gas are corrosion-resistant • Reliable, accurate instrumentation • Gas tight configuration of the blower (air end) and relative accessories • Recirculation system on relief valve; ATEX certification • ATEX configuration and certification
	Recovery of biogas from the bottom of landfill embankments (landfill gas)	<ul style="list-style-type: none"> • Corrosion resistance (due also to the particularly high concentration of H₂S) • No dispersion of biogas in the environment • Safe risk management 	<ul style="list-style-type: none"> • The materials in contact with the gas are corrosion-resistant • Gas tight configuration • ATEX configuration and certification
Nitrogen	Low pressure systems for plastic bulk inert convey or inert drying systems	<ul style="list-style-type: none"> • No dispersion of nitrogen in the environment • Compliance with O&G specifications and requisites (the systems are often located alongside refineries) 	<ul style="list-style-type: none"> • Gas tight configuration of the blower (air end) and relative accessories • Personalisation of the package to meet the customer's needs (including tests and the relative certifications)
	High pressure boosters combined with inertisation systems on various processes	<ul style="list-style-type: none"> • No dispersion of nitrogen in the environment • Absolute pressure values higher than 3 bar(a) • Compliance with the customer's specifications and requisites 	<ul style="list-style-type: none"> • Gas tight configuration of the blower (air end) and relative accessories • Resistant fusions, guaranteed for absolute pressure values higher than 3 bar • Personalisation of the package to meet the customer's needs (including tests and the relative certifications)
Butane	Recirculation of vapours of combustible liquefied gas on storage and transport systems (e.g. liquefied gas carriers)	<ul style="list-style-type: none"> • No dispersion of gas in the environment • Corrosion resistance • Compliance with the customer's specifications and requisites (e.g. certification on the basis of the shipping registers) 	<ul style="list-style-type: none"> • Gas tight configuration of the blower (air end) and relative accessories • Package execution entirely in AISI steel • Package certification in compliance with shipping register standards
Flue gas	Recovery of gas from combustion processes	<ul style="list-style-type: none"> • No dispersion of gas in the environment • Corrosion resistance • Compliance with the customer's specifications and requisites (e.g. certification on the basis of the shipping registers) 	<ul style="list-style-type: none"> • Gas tight configuration of the blower (air end) and relative accessories. In addition, a mechanical seal system with barrier is provided where necessary • The materials in contact with the pumped gas are steel, or coated • Integrated system for washing the rotor chamber with solvent
Methane	Recovery of methane from mining basins	<ul style="list-style-type: none"> • No dispersion of gas in the environment • Compliance with the customer's specifications and requisites • Blower unit with increased inherent safety level 	<ul style="list-style-type: none"> • Gas tight configuration of the blower (air end) and relative instrumentation for monitoring the operating parameters in fully safe conditions • ATEX II certification (cat.2) of the blower unit • Thicker silencers
	Marine motor supply (ships)	<ul style="list-style-type: none"> • No dispersion of gas in the environment • Conformity with regulations in force for ship movements in docking areas • Compliance with the customer's specifications and requisites (e.g. certification on the basis of the shipping registers) 	<ul style="list-style-type: none"> • Gas tight configuration of the blower (air end) and relative accessories • Package certification in compliance with shipping register standards
Nitrogen with traces of methanol	Methanol production systems	<ul style="list-style-type: none"> • No dispersion of nitrogen and methanol in the environment • Absolute pressure values higher than 3.7 bar(a), with a suction pressure of 3.3 bar(a) • Compliance with the customer's specifications and requisites 	<ul style="list-style-type: none"> • Gas tight configuration of the blower (air end) and relative accessories • Resistant fusions, guaranteed for absolute pressure values higher than 3 bar • Bare shaft complete with double mechanical seals flushed with nitrogen

Premium Solutions for Gas and Biogas Handling

Robox Gas and Biogas solutions are especially developed for the conveying and compression of biogas, as well as natural and landfill gases, special gases in the process industry, wastewater treatment and power generation plants.

Robox packages have been certified according to the most important and recent EC guideline 94/9/EC (ATEX) - group II in category 2, in order to guarantee the best safety usage in this range of applications.

ROBOX BIO&GAS



Blower stage: with gastight input shaft sealing. It is available, as optional, the blower with a special anticorrosion coating protecting all the blower's components in contact with the gas. The blower is explosion and burst proof tested.

Suction silencer: 1.3 bar overpressure PED certificated special design silencer, built in hot galvanized steel with drainage and burst-proof tested. It is also available in the stainless steel version as optional.



Baseframe with discharge silencer: 1.3 bar overpressure PED certificated baseplate and special design discharge silencer, built in hot galvanized steel with drainage device and burst proof tested. It is also available in the stainless steel version as optional.



Instruments panel

- Inlet and outlet pressure gauge indicators: manometer with stainless steel accessories (tap and pipes) in ATEX version.
- Temperature protection switch in ATEX version
- Vibration sensors in ATEX version
- Pressure protection switches (optional)



Spark safe belt guard in stainless steel

Benefits at a glance

Pressure up to 1,000 mbar(g)
vacuum up to 500 mbar(g)
Capacity up to 2,850 m³/h

- Compact
- Reliable
- Minimal wear and maintenance
- ATEX certified

Pressure regulator with bypass for keeping outlet pressure constant (optional). The standard version is equipped with a safety relief valve and a non-return VRC valve in ATEX version.

Axial compensators in suction and discharge side in stainless steel.

The following components are available in addition to the standard version:

- Sound enclosure
- Bypass unloading valve
- Stainless steel gas humidity drainage system with tank

Other special designs are available upon request.

Performance

	Robox Frame 1	Robox Frame 2	Robox Frame 3
Blower Size	RBS 15-25-35	RBS 35-45-46-55-65	RBS 65-66-75-85-86
Pressure max.(mbar)	1000	1000	1000
Capacity (m³/h)	240 - 400	400 - 1080	1370 - 2850

Overall Dimensions

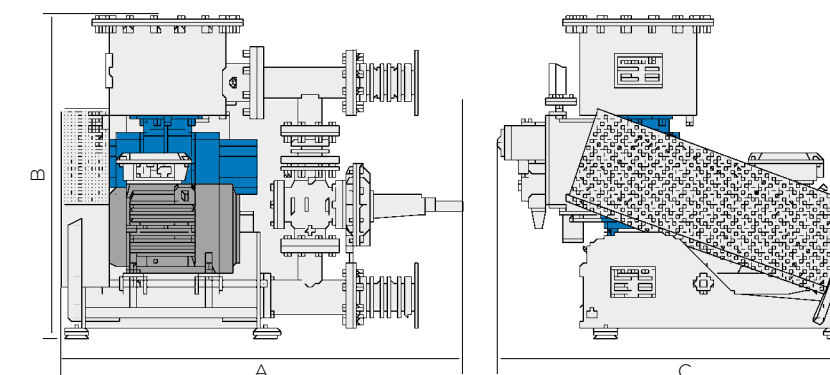

Blower Package	Robox Frame 1				Robox Frame 2				Robox Frame 3				
	RBS				RBS				RBS				
EL	15	25	35	35	45	46	55	65	65	66	75	85	86
A	844	882	882	1161	1161	1211	1196	1236	1630	1630	1630	1630	1670
B	745	745	745	1070	1070	1070	1122	1122	1595	1435	1515	1515	1515
C	912	912	985	1265	1265	1265	1265	1265	1695	1695	1695	1695	1695
Kg*	75	80	235	245	245	245	295	310	435	465	495	535	605

* Without motor

CRBIO - GRBIO



Blower package groups, assembled on a skid, developed for the conveying and compression of biogas, available with pulley belt transmission or with direct coupling.

Blower stage: with gastight sealing of the driving shaft. It is available, optionally, the blower with a special anticorrosion coating protecting all the blower's components in contact with the gas. The blower is explosion and burst proof tested.



Non return valve



Bypass safety relief valve



Coupling guards in ATEX version

Galvanized and/or painted piping

Steel base with anti-vibration mounts

The following components are available in addition to the standard version:

- By-pass safety relief valve
- Inlet and outlet pressure gauge indicators in ATEX version
- Temperature protection switch in ATEX version

Benefits at a glance

- Pressure up to 400 mbar(g)
- Vacuum up to 500 mbar(g)
- Capacity up to 2,850 m³/h
- Simple configuration
- Cost efficient
- Reliable
- Minimal wear and maintenance
- ATEX certified

Performance

	CRBIO/GRBIO 1 Frame 1	CRBIO/GRBIO 2 Frame 2	CRBIO/GRBIO 3 Frame 3
Blower Size	15-25	35-45-46-55-65	75-85-86
Pressure max (mbar)	400	400	400
Capacity min/max (m ³ /h)	40 / 350	100 / 2040	570 / 3280

Overall Dimensions

CRBIO

Rotary lobe blower package with direct coupling

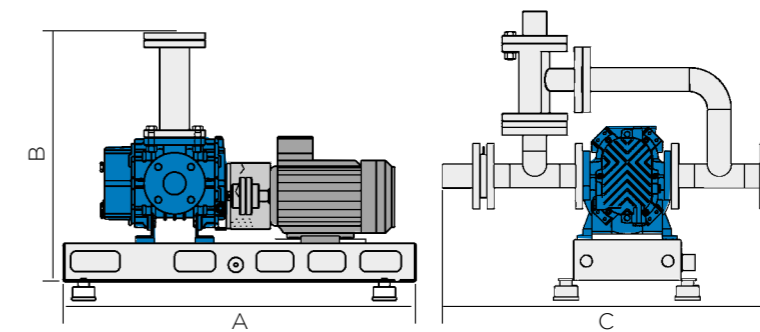

Blower Package EL	CRBIO Frame 1				CRBIO Frame 2				CRBIO Frame 3		
	15	25	35	45	46	55	65	66	75	85	86
A	950	950	950	950	1100	1800	1800	1800	1800	1800	1800
B	630	630	670	670	670	1035	1035	1155	1065	1185	1185
C	726	726	822	822	822	815	815	815	1410	1410	1410

GRBIO

Rotary lobe blower package with pulley-belt transmission

Maximum uptime. Extending performance.

We provide a range of services to ensure our customers' machines are well maintained to deliver maximum performance.

We offer preventative and planned maintenance programs, genuine parts, on-site service, professional maintenance and efficient training.

Within our service portfolio, you will find different options and services needed for optimal performance, maximum uptime and operating efficiency from your Robuschi equipment.

Visit us:

www.robuschi.com

www.gardnerdenver.com/Industrials

Scan the QR code to get it more



GARDNER DENVER S.r.l. **Divisione ROBUSCHI**

Manufacturing facilities

Via S. Leonardo, 71/A
43122 Parma - Italy
Phone: +39 0521 274 911

Filiale di Milano
Phone: +39 02 51 62 80 65

Filiale di Padova
Phone: +39 049 807 8260

info.italy@gardnerdenver.com

ROBUSCHI Benelux BV **Netherlands**

Kanaaldijk 100
6956 AX Spankeren
Netherlands
Phone: +31 313 415 570
robuschi-benelux@gardnerdenver.com

GARDNER DENVER Ltd. **United Kingdom**

Claybrook Drive,
Washford Industrial Estate
Redditch, B98 0DS - UK
Phone: +44 1527 838 200
sales.red@gardnerdenver.com