

DATA SHEET

VXLF 2.400

ROTARY VANE VACUUM PUMPS

oil-free

air-cooled

MAKE IT BECKER.

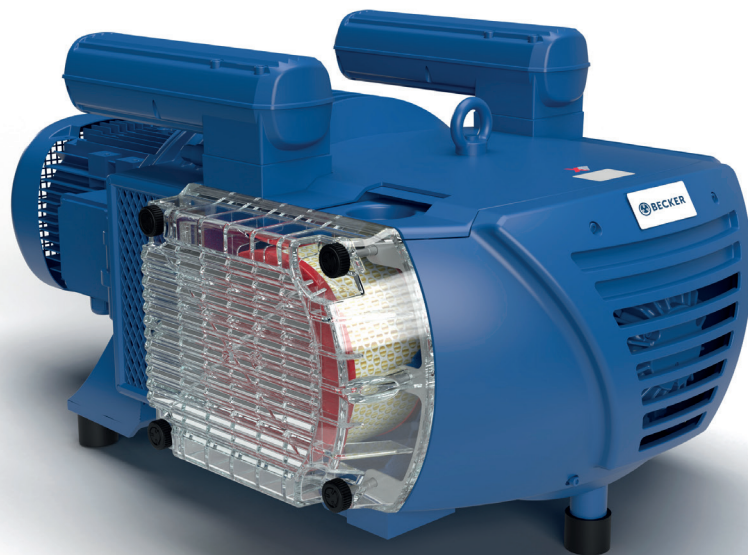
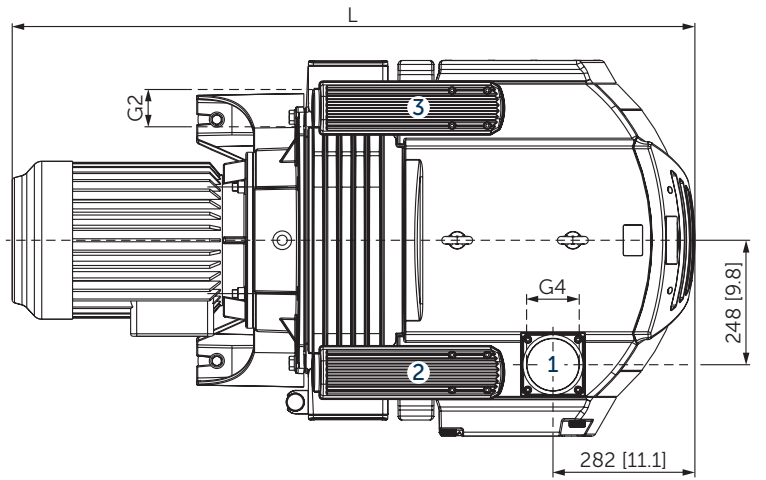
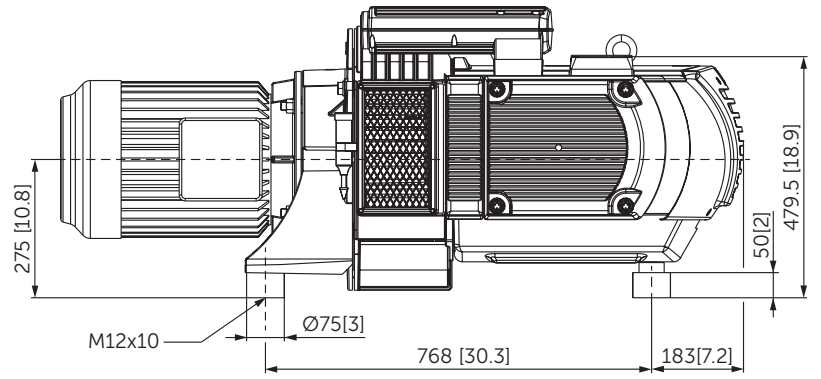
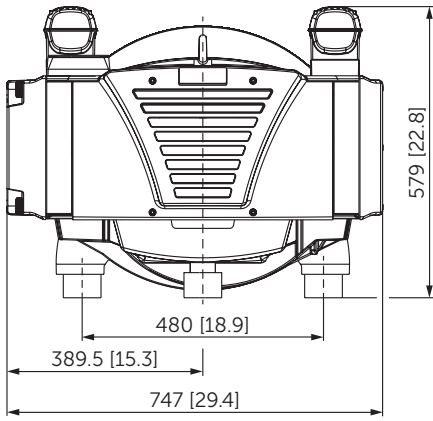

figure VXLF 2.250



- 1 Vacuum connection (G4)
- 2 Vacuum relief valve with silencer
- 3 Blow-off valve with silencer
- Including integrated suction air filter
- The motor illustration may vary.
- Dimensions in mm [inch]

Suction air rate		Vacuum absolute		Emission sound pressure level ¹⁾		Weight w/o motor
m ³ /h		mbar		dB(A)		kg
50 Hz	60 Hz	50 Hz	60 Hz	50 Hz	60 Hz	
390	460	200	200	77	79	248

¹⁾ According to DIN EN ISO 3744 (KpA = 3 dB(A)), 1 m [39.4 inch] distance, at medium load, both connection sides piped

3~ Motors												L	
#	50 Hz				60 Hz				Version	Weight kg	mm [inch]		
	kW	V	min ⁻¹	A	kW	V	min ⁻¹	A					
01	7.5	Δ400	IE3	738	19.9	9.0	Δ460	IE3	886	20.1	UL(E235514) • CSA CC329B IP55 • ISO F • bimetal	177	1477 [58.2]
							Δ400		881	21.4			
02						9.0	YY230/Y460	IE3	888	43.4/21.7	UL(E235514) • CSA CC329B IP55 • ISO F • bimetal	177	1477 [58.2]
							YY208		886	55.3			
03	7.5	Δ200/Y350	IE3	736	37.2/21.5	9.0	Δ220/Y380-400	IE3	882	39.1/22.6-22	UL(E235514) • CSA CC329B IP55 • ISO F • bimetal	177	1477 [58.2]
							Δ200/Y350		876	42.9/24.8			
04						9.0	Δ400/Y690	IE3	878	22.3/12.9	UL(E235514) • CSA CC329B IP55 • ISO F • bimetal	177	1477 [58.2]

- Current consumption and rotation speed may vary. Tolerance in each case -1.5/+2%

SERIES X: BECKER INNOVATION WITH TOP WARRANTY

Equipped with specially developed vanes, these oil-free rotary vane pumps distinguish themselves by high abrasion resistance, and with that extremely long service lives. Due to the low wear there is also minimal dust, so the series X pumps are perfectly suited for precision processes under clean room conditions.

This innovation branded by Becker is outstanding not only because of its 100 percent oil-free operation, excellent degree of efficiency and low power consumption.

In the area of sensitive vacuum, series X also guarantees precise low-pulsation air conduction.

Becker guarantees for these pumps a vane life-time of 20,000 operating hours or a maximum of 3 years. The enhanced longevity of X series pumps also extends service life intervals, and can cut out the need for frequent service visits with costly pump failures now no longer an issue.



ADVANTAGES

- Quick, clean and quiet
- Oil-free
- Wear resistant
- Energy saving
- Long-life reliability

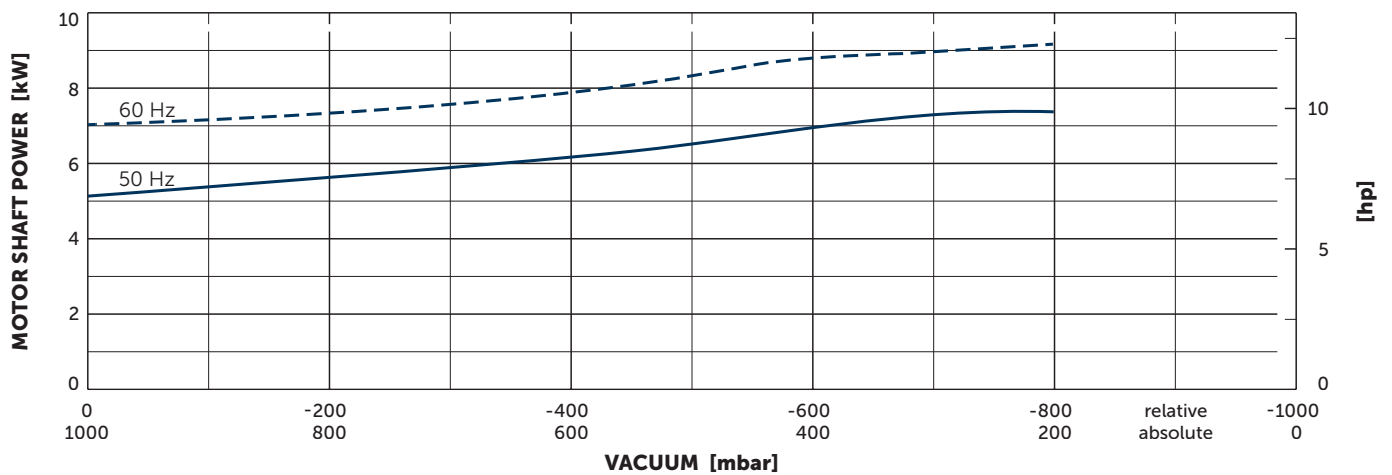
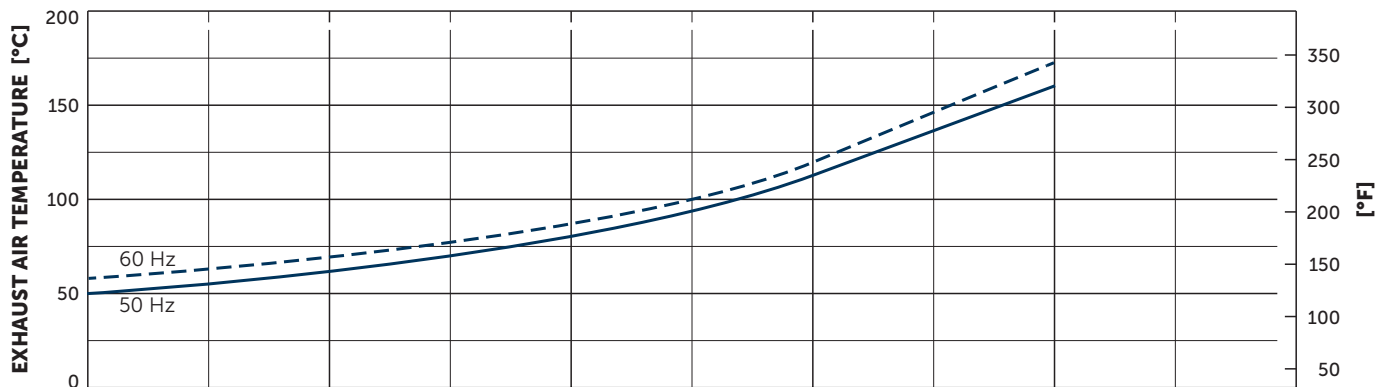
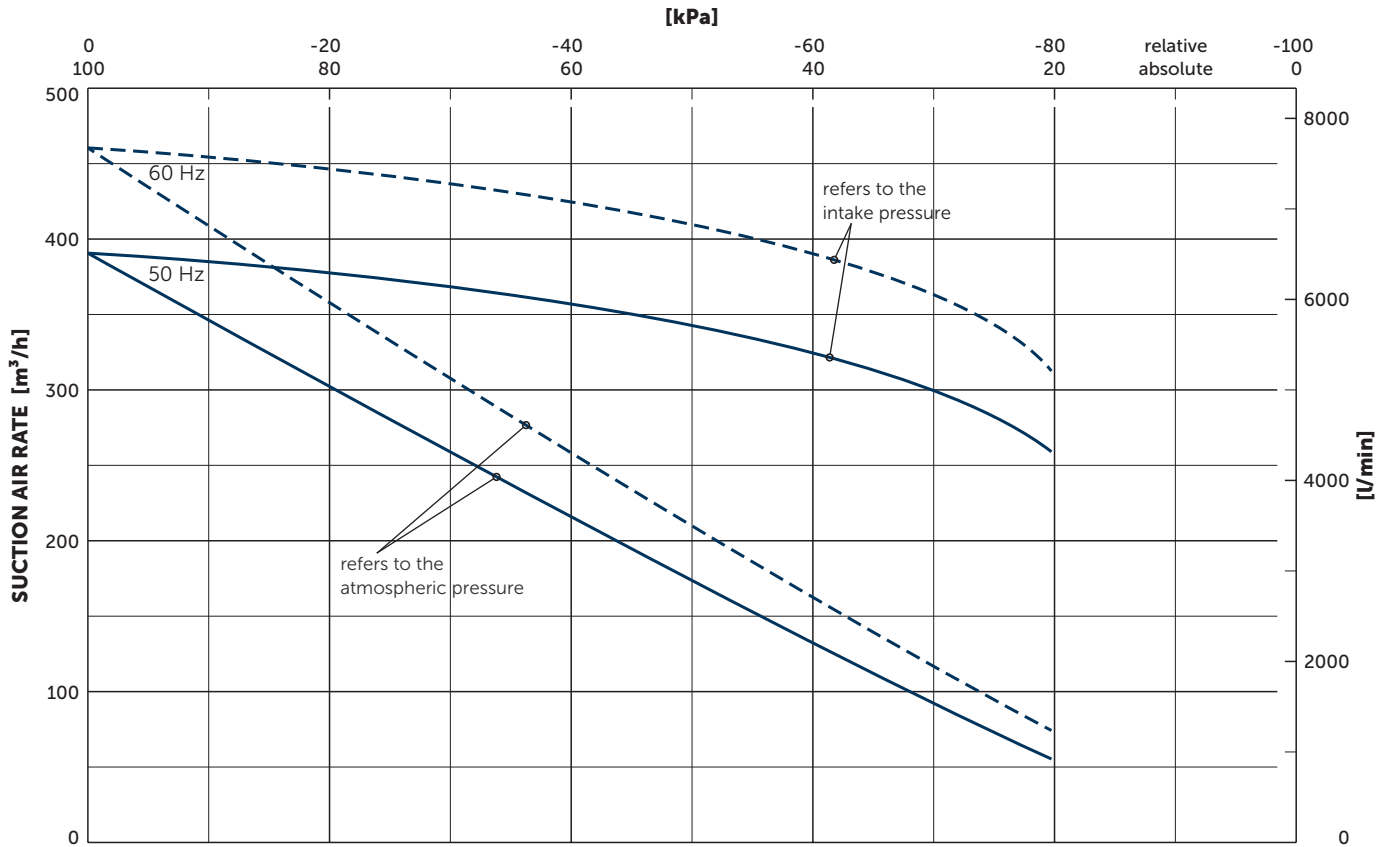

Reference data (atmosphere): 1000 mbar (100 kPa), 20°C (68°F)
Tolerance: ±5%

+ VARIANTS AND ACCESSORIES

- Integrated non return valve
- External suction filter¹⁾
- Sound proof box SH 12¹⁾



Example for an external suction filter



Sound proof box SH 12

¹⁾ See separate data sheet

- Possible combinations on request



MAKE IT BECKER.