

DATENBLATT

VARIAIR KVT 3.100/0-400

DREHSCHIEBER- VAKUUMPUMPEN

trockenlaufend, luftgekühlt
Frequenzumrichter



MAKE IT BECKER.

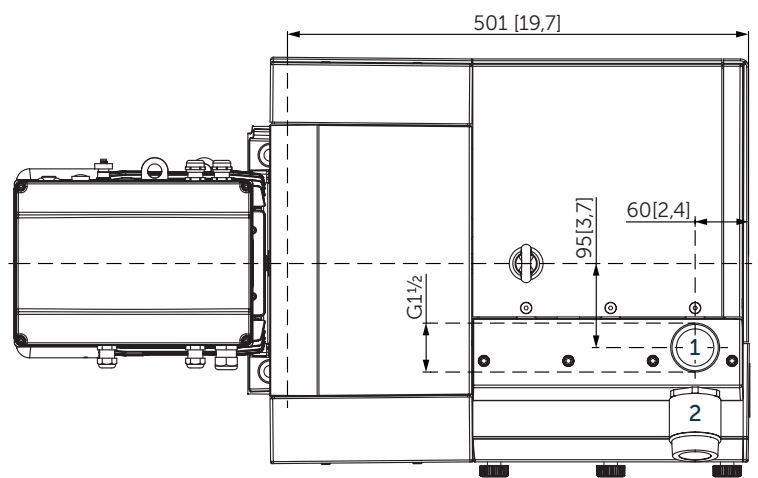
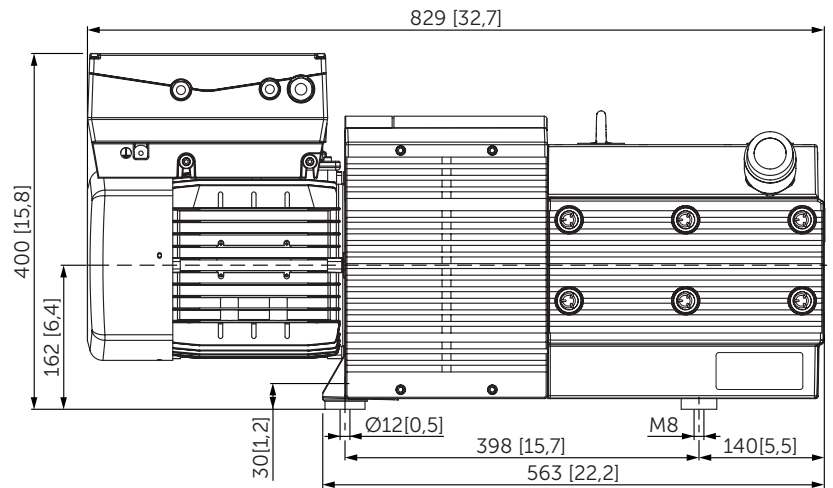
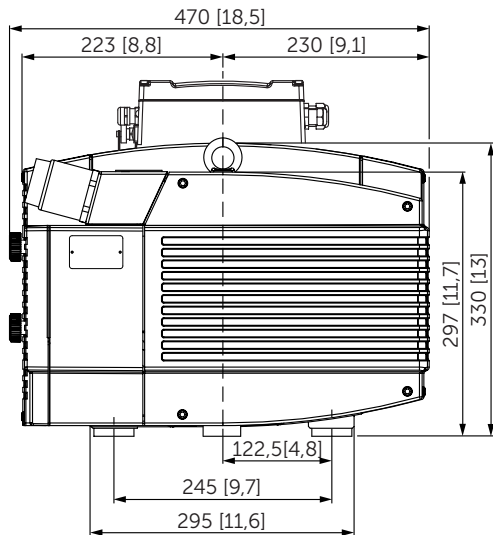

Abbildung VARIAIR KVT 3.80-0-400



- 1 Sauganschluss (G1½)
- 2 Vakuumregulierventil
 - Inklusive integriertem Ansaugfilter und Abblaseventil
 - Die Motorabbildung kann variieren.
 - Abmessungen in mm [inch]

Saugluftmenge	Vakuum absolut	Frequenz	Emissions-Schalldruckpegel ¹⁾	Gewicht		
m ³ /h max.	mbar max.	Hz	dB(A) @ -600 mbar (40 Hz)	kg	Frequenzumrichter VAU4/4	A max.
112	100	30-60	77	109,5	4,0 kW 400-480 V ±10% 50/60 Hz	16

¹⁾ Nach DIN EN ISO 3744 (KpA = 3 dB(A)), 1 m [39,4 inch] Abstand, mittlere Druckbelastung, Saug- und Druckseite abgeleitet

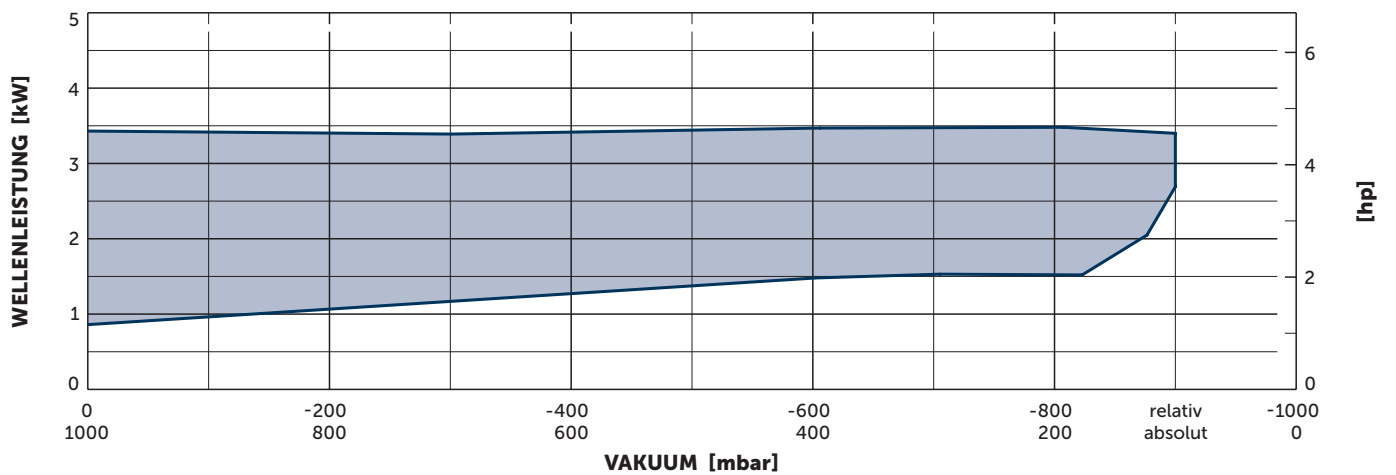
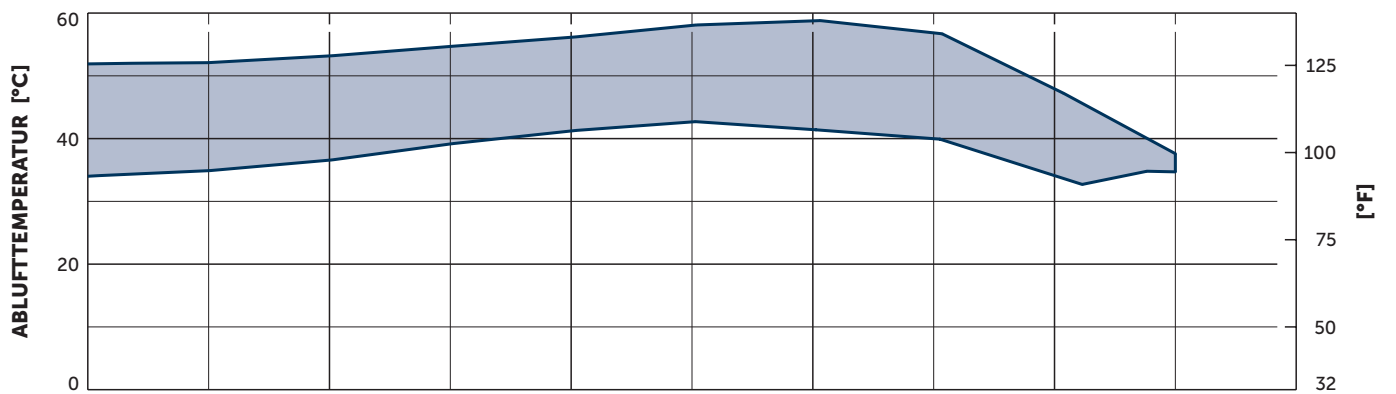
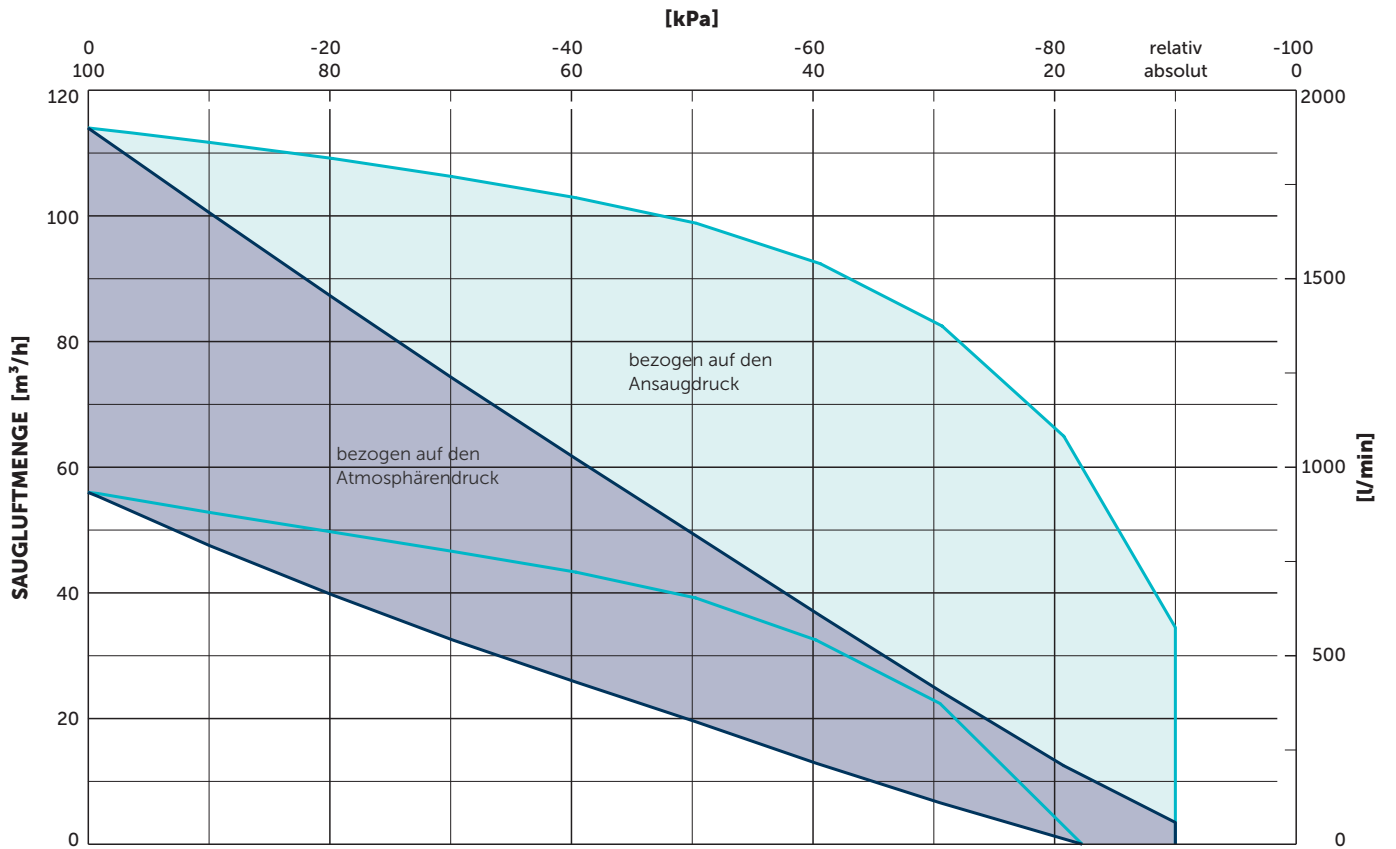

Bezugsdaten (Atmosphäre): 1000 mbar (100 kPa), 20°C (68°F)
Toleranz: ±5%



MAKE IT BECKER.