

DATA SHEET

KVT 3.60

ROTARY VANE VACUUM PUMPS

oil-free

air-cooled

MAKE IT BECKER.



figure KVT 3.140

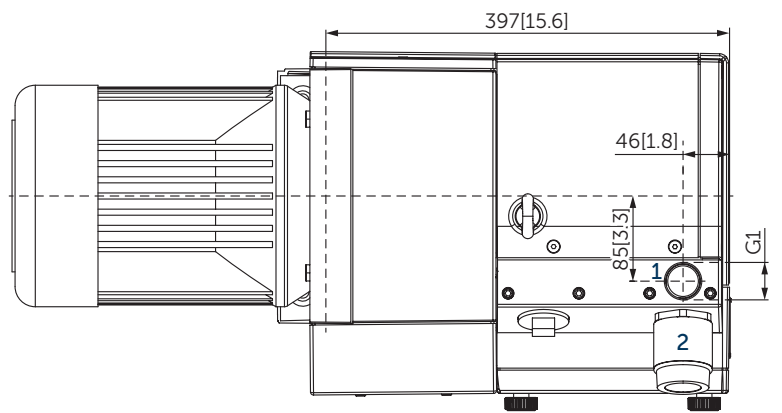
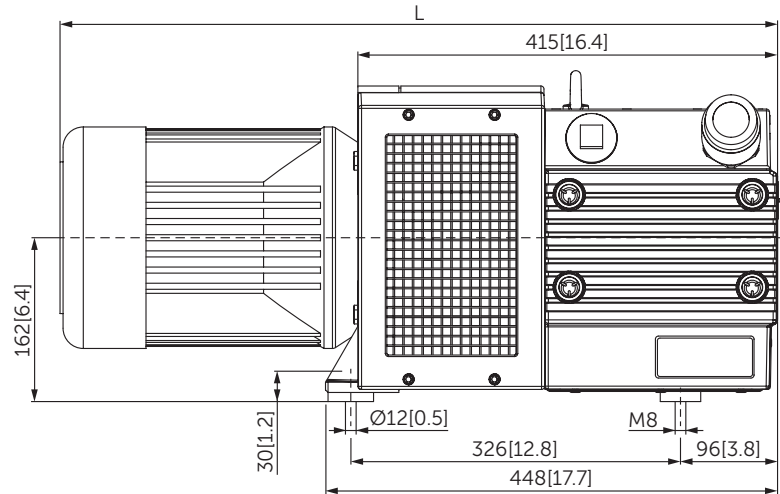
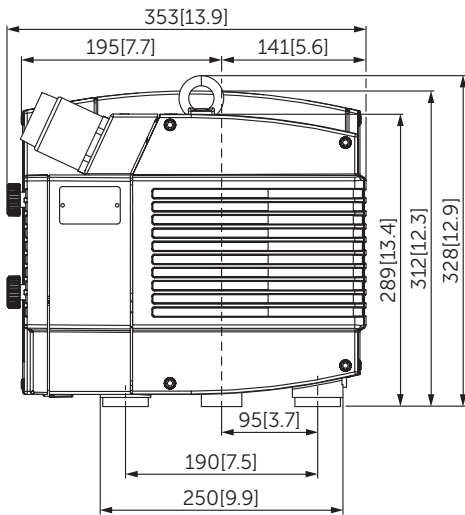

- 1 Vacuum connection (G1)
- 2 Vacuum regulating valve
- Including integrated suction air filter and blow-off valve
- The motor illustration may vary.
- Dimensions in mm [inch]

Suction air rate		Vacuum absolute		Emission sound pressure level ¹⁾		Weight w/o motor
m ³ /h		mbar		dB(A)		kg
50 Hz	60 Hz	50 Hz	60 Hz	50 Hz	60 Hz	
55	66	100	100	71	73	47

¹⁾ According to DIN EN ISO 3744 (KpA = 3 dB(A)), 1 m [39.4 inch] distance, at medium load, both connection sides piped

3~ Motors											L		
#	50 Hz				60 Hz				Version	Weight kg	mm [inch]		
	kW	V	min ⁻¹	A	kW	V	min ⁻¹	A					
01	2.2	Δ230/Y400	IE3	1440	8.2/4.8	2.6	Δ265/Y460	IE3	1735	8.2/4.8	IP55 • ISO F • bimetal	29	704 [27.7]
							Δ230/Y400			1705			
02						2.6	YY230/Y460	IE3	1763	9.3/4.6	UL(E365362) • CSA CC334B IP55 • ISO F • bimetal	37	747 [29.4]
							YY208			1754			
03	2.2	Δ200/Y350	IE3	1470	10.4/6.0	2.6	Δ220/Y380-400	IE3	1760	10.0/5.8–5.8	UL(E365362) • CSA CC334B IP55 • ISO F • bimetal	37	747 [29.4]
							Δ200/Y350			1755			
04						2.6	Δ400/Y690	IE3	1760	5.3/3.1	UL(E365362) • CSA CC334B IP55 • ISO F • bimetal	37	747 [29.4]

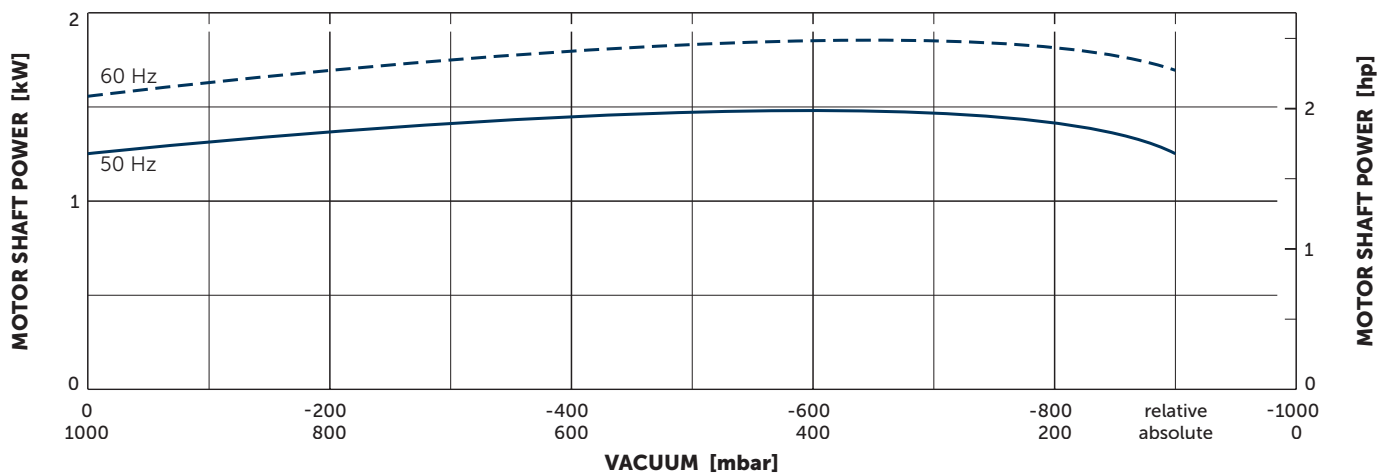
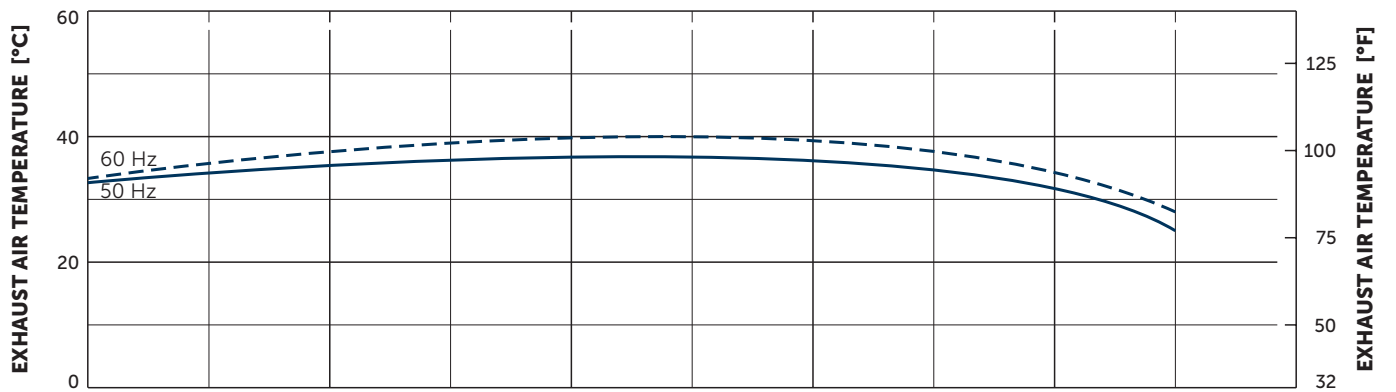
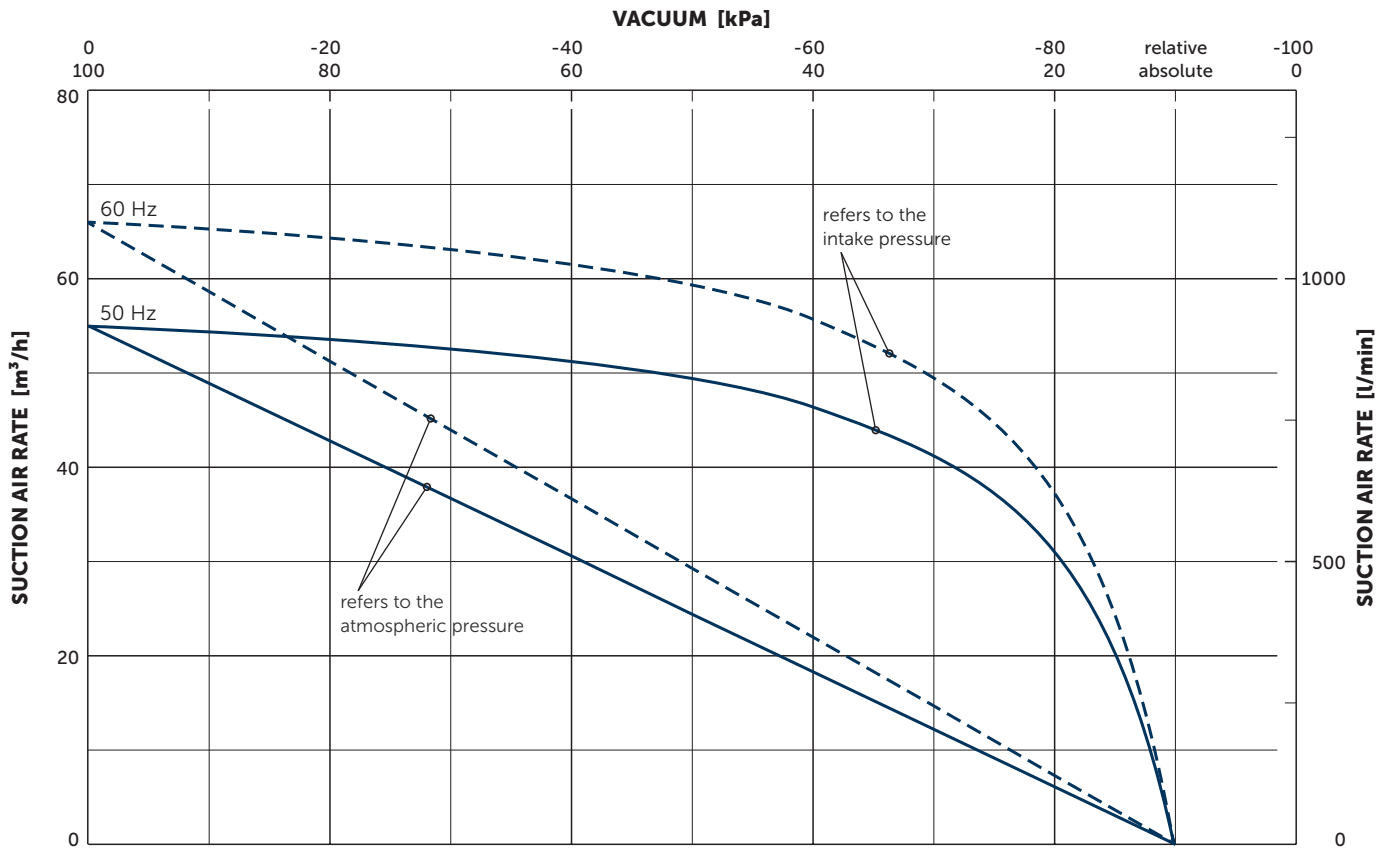

Reference data (atmosphere): 1000 mbar (100 kPa), 20°C (68°F)
Tolerance: ±5%

+ VARIANTS AND ACCESSORIES

KVX 3.60

SERIES X: BECKER INNOVATION WITH TOP WARRANTY

Equipped with specially developed vanes, these oil-free rotary vane pumps distinguish themselves by high abrasion resistance, and with that extremely long service lives. Due to the low wear there is also minimal dust, so the series X pumps are perfectly suited for precision processes under clean room conditions.

This innovation branded by Becker is outstanding not only because of its 100 percent oil-free operation, excellent degree of efficiency and low power consumption.

In the area of sensitive vacuum, series X also guarantees precise low-pulsation air conduction.

Becker guarantees for these pumps a vane life-time of 20,000 operating hours or a maximum of 3 years. The enhanced longevity of X series pumps also extends service life intervals, and can cut out the need for frequent service visits with costly pump failures now no longer an issue.

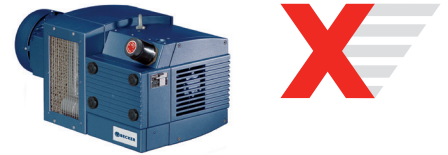

ADVANTAGES

- Quick, clean and quiet
- Oil-free
- Wear resistant
- Energy saving
- Long-life reliability

OTHER VARIANTS AND ACCESSORIES

- **KVT 3.60/0-54** with exhaust connection
- Increased corrosion protection
- External suction filter¹⁾
- Sound proof box SH 13¹⁾

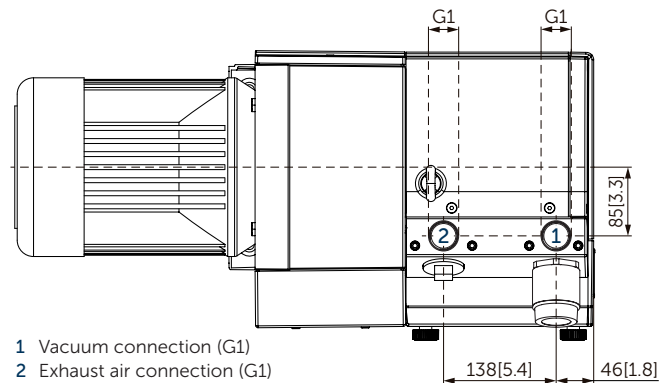

Example for an external suction filter



Sound proof box SH 13

¹⁾ See separate data sheet

- Possible combinations on request



MAKE IT BECKER.